

**This camera manual library is for reference and historical purposes, all rights reserved.**

**This page is copyright by mike@butkus.org M. Butkus, N.J.**

**This page may not be sold or distributed without the expressed permission of the producer**

**I have no connection with any camera company**

**If you find this manual useful, how about a donation of \$3 to: M. Butkus, 29 Lake Ave., High Bridge, NJ 08829-1701 and send your E-mail address too so I can thank you. Most other places would charge you \$7.50 for a electronic copy or \$18.00 for a hard to read Xerox copy. These donations allow me to continue to buy new manuals and maintain these pages. It'll make you feel better, won't it?**

**If you use Pay Pal, use the link below. Use the above address for a check, M.O. or cash. Use the E-mail of butkusmi@ptd.net for PayPal.**



[back to my "Orphancameras" manuals /flash and light meter site](#)

Only one "donation" needed per manual, not per multiple section of a manual !

The large manuals are split only for easy download size.

# Canon SURE SHOT / SURE SHOT

MAX

MAX

DATA



**E**

INSTRUCTIONS  
English Edition

**F**

MODE D'EMPLOI  
Edition française

**S**

INSTRUCCIONES  
Edición española

# Nomenclature

① Frame Counter

② Shutter Button

③ Auto Focus Window

④ Lens

⑤ Lens Cover Open/Close Switch  
(ON/OFF Button)

⑥ AE Metering Window

⑦ Auto Focus Window

⑧ View Finder Window

⑨ Self-timer Button

⑩ Flash

⑪ Red-Eye Reduction  
Lamp/Self-timer  
Lamp

⑫ Battery Cover

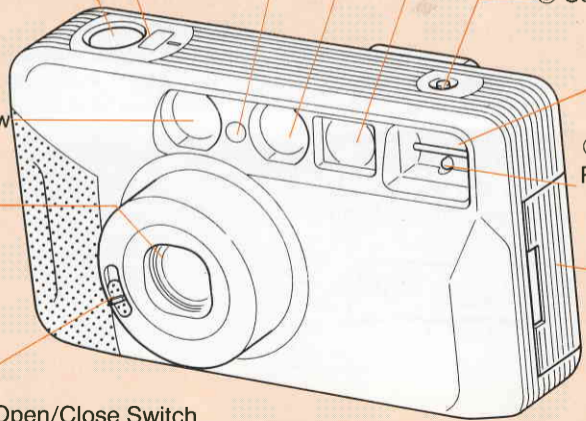

\* 1

1

\* 1

\* 1

\* 1

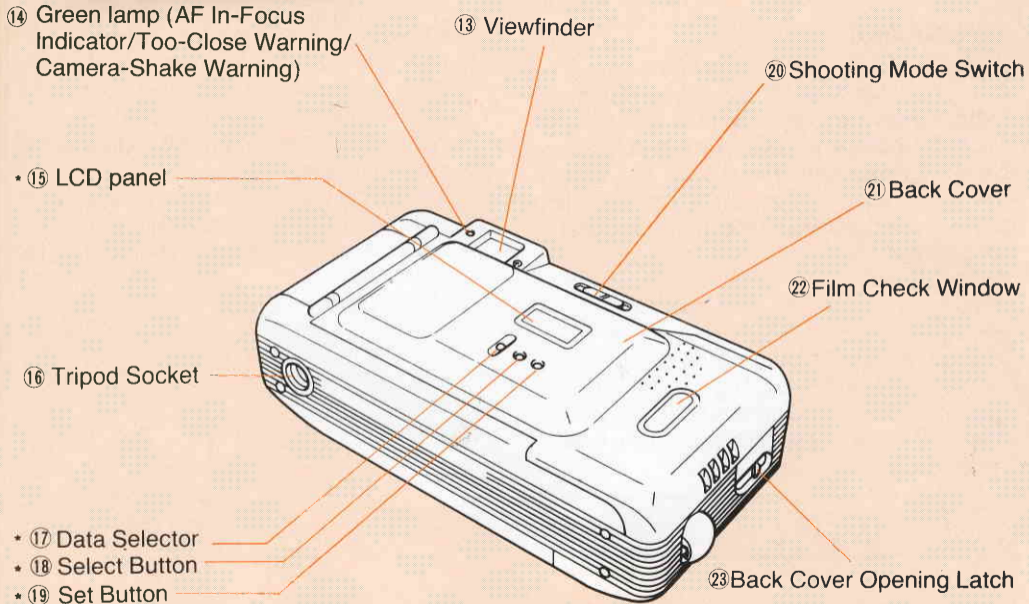

# Nomenclature

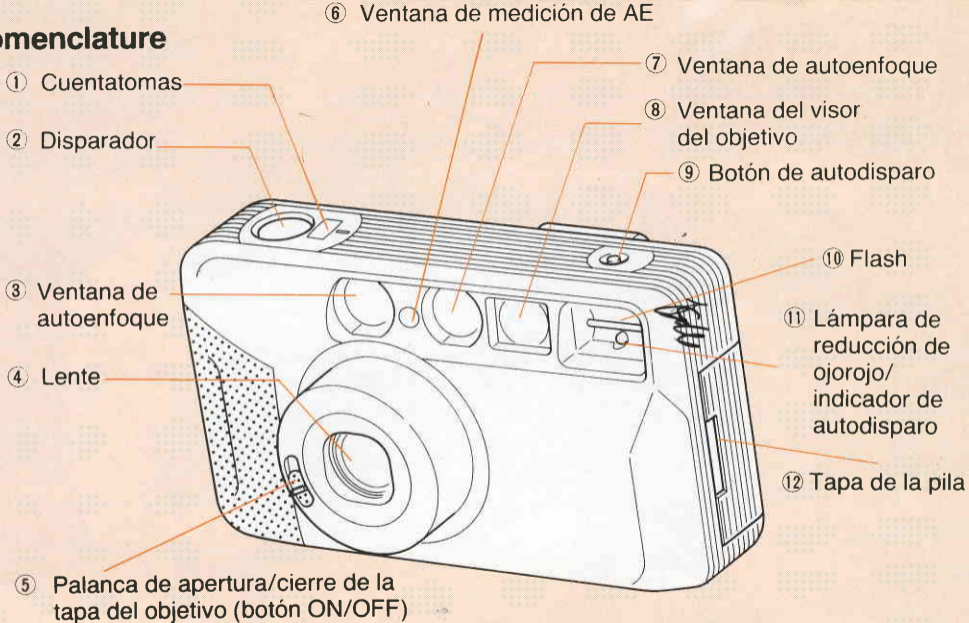

# Table of Contents

## Handling Precautions

<b>I. Shooting Preparations</b> .....	<b>15</b>
1. Loading and Checking the Battery .....	19
2. Holding the Camera .....	25
3. Shutter Button Action .....	27
4. Loading the Film .....	29
<b>II. Basic Picture Taking</b> .....	
1. Turn on the Camera .....	35
2. Select the Shooting Mode .....	37
3. Take Pictures .....	45
4. Remove the Film .....	53
<b>III. Other operations</b> .....	
1. Focus Lock .....	57
2. Self-timer Photography .....	61
<b>IV. Additional Functions for the SURE SHOT MAX DATE</b> .....	
1. Selecting the Imprint Format .....	65
2. Date/Time Setting .....	67
<b>V. Specifications</b> .....	<b>73</b>

## Handling Precautions

---

- 1) This camera is not resistant to water, and should not be used outdoors if raining or snowing. If accidentally dropped in water, contact an authorized Canon service facility. Keep the camera out of salt spray and excessive humidity. If used at the beach, clean it thoroughly afterward with a dry cloth.
- 2) Store the camera in a cool, dry, dust-free place. Be sure to keep the camera out of direct sunlight, and away from "hot spots" such as the trunk or rear window shelf of a car. Avoid places where mothballs are used, and use a dessicant in excessive humidity.
- 3) Do not attempt to disassemble the camera yourself, due to the high-voltage circuitry inside.
- 4) The battery may explode or cause burns if disassembled, recharged, shorted, exposed to high temperatures, or disposed of in fire.
- 5) Use a blower brush to remove dust and sand from the lens and inside the camera. Do not apply any fluids to the lens or body. Take the camera to an authorized Canon service facility for a more thorough cleaning if necessary.
- 6) Film passing through X-ray examinations at an airport may be exposed and ruined even when loaded in the camera. Request a handchecked inspection to avoid damage.
- 7) Color reproduction may be adversely affected if film is left in the camera for a long time. **Always** develop exposed film promptly.

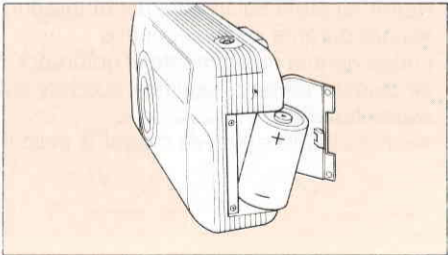
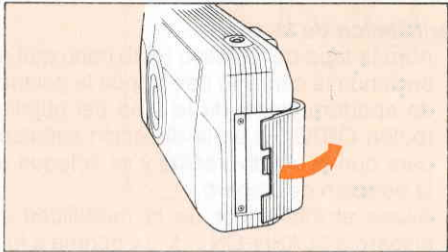

## 1. Loading and Checking the Battery

---

This camera uses one CR123A three-volt lithium battery.

- 1) Slide the battery cover in the direction of the arrow to open.
- 2) Load the battery so that its terminals face in the direction shown in the illustration.
- 3) Close the battery cover.



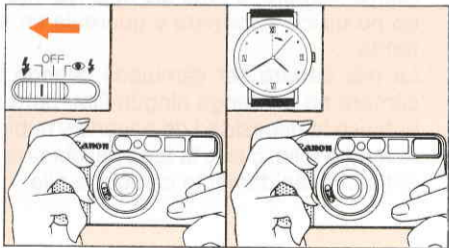
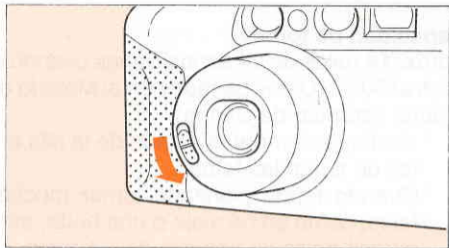

### Checking the Battery

- 1) Open the lens cover (this turns the power on) by sliding the lens cover open/close switch in the direction shown, and the lens moves out to the ready position.
- 2) Set the shooting mode switch to Flash-ON ( ⚡ ) and press the shutter button completely to fire the flash.
- 3) Remove your finger only from the shutter button, and wait for six seconds.
- 4) Then press the shutter button again and the battery power is sufficient if the flash fires.
  - Check the battery before loading the film.

---

## **Shooting Capacity**

Approx. 18 rolls of 24-exp. film with 50% flash use. (Data based on Canon's Standard Test Method).

- \* Always check the battery before taking pictures.
- \* When you intend to take many pictures, such as on a trip or at a wedding, be sure to take along a spare battery.
- \* When the camera is not in use, be sure to close the lens cover keep the camera in its case.
- \* The battery should be changed when no film is loaded, however if you must change it in mid-roll, close the lens cover and then quickly change the battery.

## 2. Holding the Camera

---

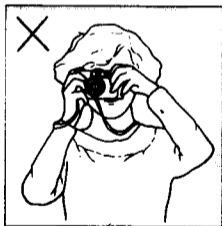
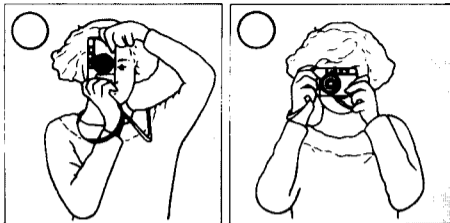

Unsharp pictures caused by “camera shake” may occur if the camera is not held steadily. Try the following technique to ensure sharp pictures.

- 1) Put the neckstrap around your neck, and hold the camera with both hands.
- 2) Keep your elbows close to your body.
- 3) Hold the camera lightly against your nose and look through the viewfinder.

\* We recommend using ISO 200 or ISO 400 film to decrease the chances of camera shake by providing higher shutter speeds.

\* Be careful to keep hair and fingers from blocking the lens, AE metering/Auto Focus windows, or flash when holding the camera.

\* Do not grasp the lens barrel when holding the camera.

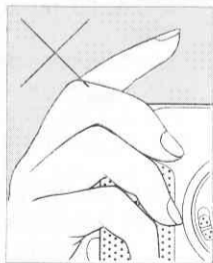
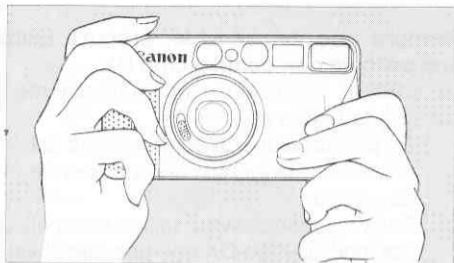

### 3. Shutter Button Action

---

The shutter button activates two functions depending on the amount of pressure applied.

- 1) Press halfway for focus and metering.
- 2) Press completely to take the picture.

\* Shutter button action plays an important part in taking sharp pictures. A quick stroke with the tip of your finger or fingernail may cause unnecessary camera movement called "camera shake." Rest the ball of your finger on the shutter button, press the button halfway to focus the subject, and then press the button completely using a gentle squeezing action.

## 4. Loading the Film

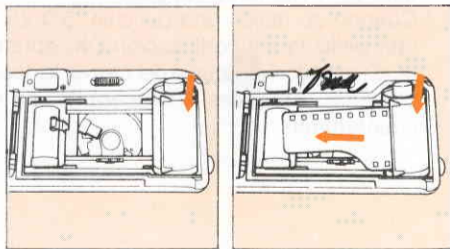
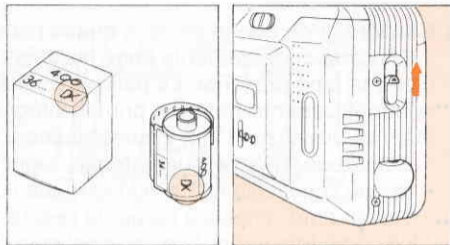

**Use only DX-coded film whenever possible.**

The camera automatically sets the film speed.

\* Any DX-coded film within the range of ISO 25-3200 can be used.

\* For slide film, use DX-coded film with a speed of ISO 25, 50, 100, 200, 400, 800, 1600, or 3200.

\* Non-DX-coded film cartridges are automatically registered as ISO 25.

- 1) Slide the back cover latch up to open the back cover.
- 2) Insert the flat end of the film cartridge in first.
- 3) Carefully pull the film tip across until it reaches the film tip position mark.

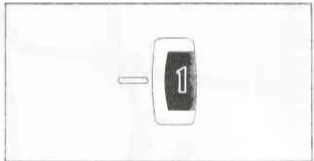
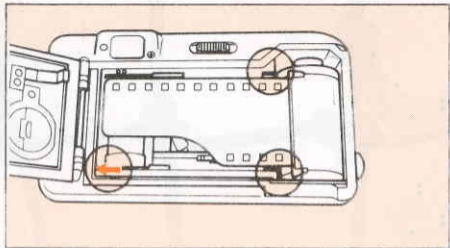

4) Make sure the film lies flat and is positioned properly between the film guides, then close the back cover. The film automatically advances to the first frame, and "1" appears in the frame counter.

\* If "S" shows in the frame counter, the film has been loaded incorrectly. Reload the film.

\* No photos can be taken if the film is loaded incorrectly.

\* When using ISO 25 film or non-DX-coded film, press the shutter button after closing the back cover. "1" will appear in the frame counter.

**[II] Prises de vues**

**[II] Fotografía básica**

**[II] Basic Picture Taking**

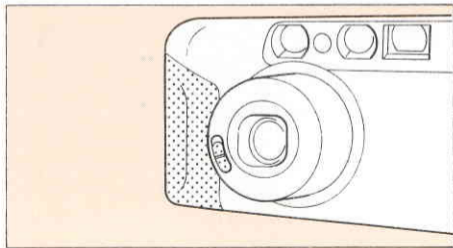
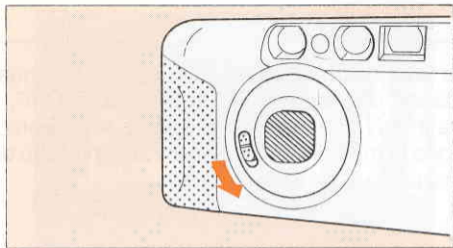

## 1. Turn on the Camera

Move the lens cover open/close switch to the bottom (  ) OPEN position.



## 2. Select the Shooting Mode

---

The Sure Shot Max/Max Date has three shooting modes: Flash-ON, Flash-OFF, and Flash-ON with Red-eye Reduction. Select the shooting mode according to the type of picture you wish to take.



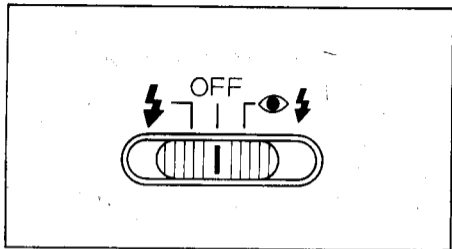

**Flash-ON ( ⚡ ):** Use this setting for fill-in flash photography in daylight or low-light flash photography of inanimate objects. The flash always fires regardless of the existing light conditions in this mode.

In this mode, the Red-Eye Reduction lamp doesn't function.

**Flash-OFF (OFF):** Use this setting for normal daylight situations and also existing light pictures such as sunsets or in locations where flash is prohibited, such as museums. The flash never fires in this mode.\*

**Flash-ON with Red-Eye Reduction ( 👁 ⚡ ):** Use this setting for flash photography of people or pets. The flash always fires regardless of the existing light conditions in this mode.\*\*

---

\* Note: When taking pictures in the Flash-OFF mode, the shutter speed will become slow in low-light situations and the camera must be kept very still. To prevent blurred pictures, mount the camera on a tripod or place it on a stable surface.

---

**\*\* Note:** Especially in pitch dark situations, flash pictures of people or pets may exhibit "red-eye." This occurs when flash illumination reflects off the retina causing eyes to appear red. If the shooting mode is set to Flash-ON with Red-Eye Reduction, an incandescent lamp in the flash illuminates when necessary for at least 1 second before exposure to contract the subject's pupils and minimize the chance of red-eye. During illumination of this red-eye reduction lamp, make sure the subject is looking at the lamp.

When the Red-Eye Reduction lamp lights, the fast blinking green lamp changes to lit continuously.

### 3. Take Pictures

---

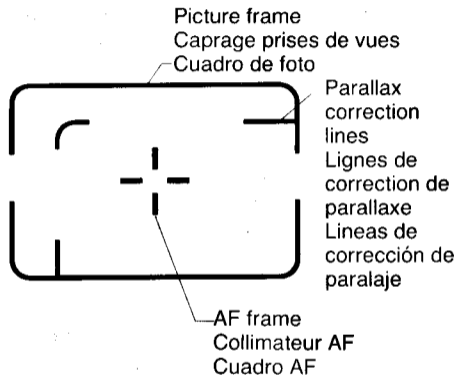

1) Compose the picture using the viewfinder and the AF frame.

\* Although Smart AF focuses most subjects, it is best to place the main subject so that it covers at least part of the AF frame in the center of the viewfinder. (For Focus Lock, see p.57)

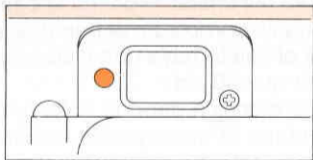
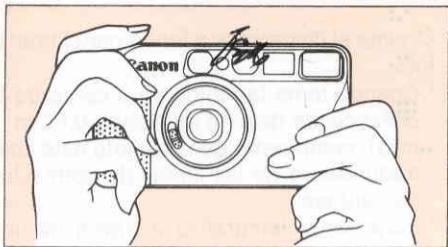

---

2) Press the shutter button halfway to focus the subject in the AF frame. The green lamp lights up steadily when the subject is in focus.

\* If the green lamp blinks slowly (4 times/second), you are too close to the subject. Move at least 0.65 m (2.1 ft.) away from the subject and refocus.

\* If the green lamp blinks rapidly (16 times/second) in the Flash OFF mode, the shutter speed will be too slow for hand-held photography. Use the flash or place the camera on a tripod to ensure sharp results.

---

3) Gently press the shutter button all the way down to take the picture.

\* When shooting at or near the closest shooting distance of 0.65 m (2.1 ft.), make sure the subject is positioned inside the parallax correction lines.

\* For shooting pictures through a window, set the camera at an appropriate angle from the camera-to-subject distance of approx more than 20 cm.

\* Care should be taken to avoid hitting or scratching the AF windows as either may lead to inaccurate focusing.

---

\* For proper exposure in the Flash-ON and Red-Eye Reduction shooting modes, be sure to stay within the range of the film in use as shown below:

**Flash Shooting Distance Range  
(using color print film)**

<b>Film Speed</b>	<b>Distance Range</b>
ISO 100	0.65—4 m (2.1—13.1 ft.)
ISO 200	0.65—5.6 m (2.1—18.4 ft.)
ISO 400	0.65—8 m (2.1—26.2 ft.)

\* Wait about 4 seconds between flash pictures for the flash to recharge.



#### 4. Remove the Film

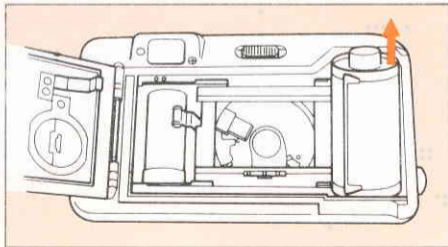
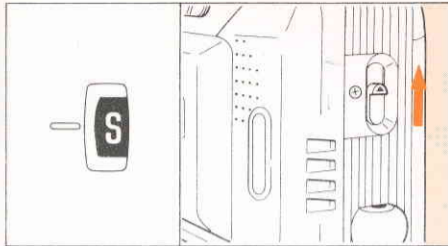

The film is rewound automatically at the end of the roll. The frame counter counts down while the film is rewinding. Film rewind stops automatically when the film has been completely rewound, and the counter shows "S".

- 1) Open the back cover by sliding the back cover opening latch in the direction of the arrow to remove the film.
- 2) **Make sure the frame counter shows "S" before opening the back cover to remove the film cartridge.**

\* If more than the number of frames specified on the film cartridge is shot, the last frame may be cut off during processing.

**[III] Autres fonctions**  
**[III] Otras operaciones**  
**[III] Other Operations**

## 1. Focus Lock

Although Smart AF focuses most subjects, use Focus Lock for subjects extremely small, extremely off-center, or if the camera is to be positioned vertically.

- 1) Center the AF frame over the subject and press the shutter button halfway. The green lamp lights steadily to indicate Focus Lock.
- 2) Keeping the shutter button pressed halfway (green lamp remains lit), recompose the picture as desired and then press the shutter button completely down to take the picture.

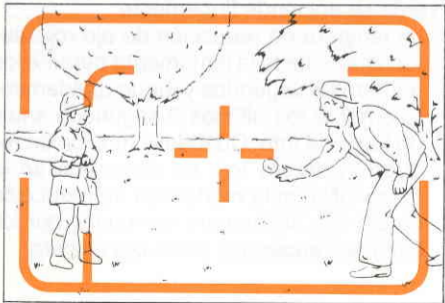
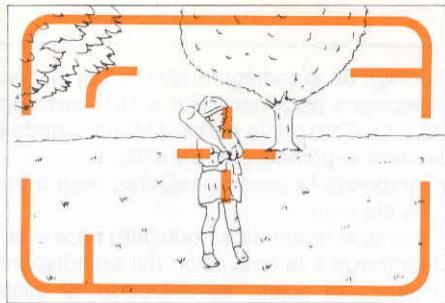

## 2. Self-timer Photography

---

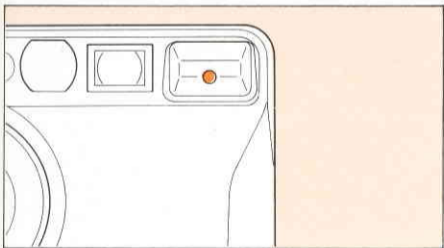
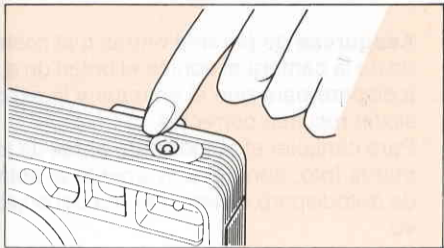

The self-timer function delays shutter release for 10 seconds to allow you to include yourself in the picture. Place the camera on a tripod or position it on a flat, steady surface.

- 1) Compose the picture while looking through the viewfinder.
- 2) Press the self-timer button for autofocus-ing and self-timer activation. When the subject is in focus, the green lamp lights up steadily.

\* The red-eye reduction/self-timer lamp starts blinking slowly for the first 8 seconds and then rapidly for the last 2 seconds before the picture is taken.

When the red-eye reduction function is triggered in the Flash ON with Red-Eye Reduction mode, the illuminates for the last 2 seconds before shutter releasing.

- 
- \* **Be sure** to stand behind or to the side of the camera when pressing the self-timer button to ensure proper focus and exposure.
  - \* To cancel the self-timer before the picture is taken, either press the self-timer button again or close the lens cover.

**[IV] Fonctions additionnelles  
pour le SURE SHOT MAX  
DATE**

**[IV] Funciones adicionales de la  
SURE SHOT MAX DATE**

**[IV] Additional Functions for the  
SURE SHOT MAX DATE**

## 1. Selecting the Imprint Format

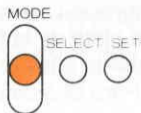

Simulated Date  
Date simulée  
Fecha simulada

The date/time can be imprinted in one of four different formats or turned off. Press MODE button to change the date format in the following sequence:

(1) Year/Month/Day



(2) Day/Hour/Minute



(3) No Imprint



(4) Month/Day/Year



(5) Day/Month/Year

## 2. Date/Time Setting

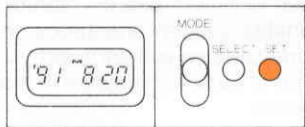
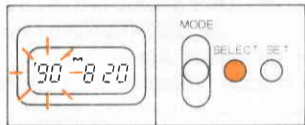
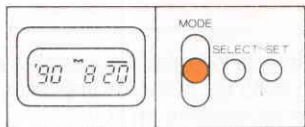

The date imprint function automatically keeps track of the correct date and time by making adjustment for leap years plus long and short months. For the initial setting, when traveling to a different time zone or when replacing the battery, set the date and time as follows:

- 1) Press MODE button to display the date or time on the LCD panel.
- 2) Press SELECT button so that the first setting position to be adjusted starts blinking.
- 3) Press SET button to input the desired number.  
\* The number increases by one each time the SET button is pressed. If the SET button is held down, the number increases quickly.
- 4) Repeat steps 2) and 3) until all positions are set. When finished, press SELECT button until all positions stop blinking.



## Replacing the date back battery

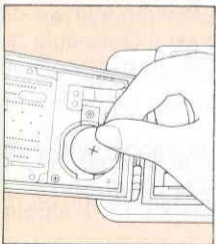
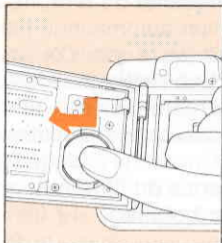
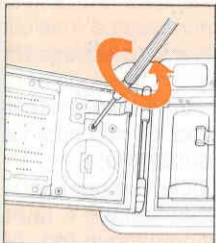

Replace the date back battery when the imprinted numerals do not appear clearly on the picture.

A battery is included in the date back at the time of purchase.

Power Source: one, 3V lithium battery,  
CR 2025 (coin-sized)

Battery Life: Approx. 3 years

1. Open the back cover of the camera and unscrew the battery chamber cover.
  2. Remove the battery.
  3. Load the new battery so that its terminals face in the direction shown in the illustration.
  4. Tighten the screw and reset the correct time and date.
- Keep batteries away from children. If swallowed, contact a physician immediately.

### *Alimentación*

**Pila:** Una pila de litio de 3V (CR 123A/DL 123A)

**Capacidad de disparo:** Aprox. 15 rollos de 24 exposiciones usando el flash al 50%.

**Verificación de la pila:** El disparo es posible cuando se ilumina el piloto verde al pulsar el SW I. (Véase página 00).

### *Tamaño*

**Dimensiones:** 125 (An)×68 (Al)×38 (F) mm

**Peso:** 220 gr sin pila

### **Especificaciones adicionales para la SURE SHOT MAX DATE**

**Función de impresión:** Función de impresión incorporada mediante LCD del tipo de transmisión y calendario automático programado hasta el año 2019 (compensa automáticamente los meses largos y cortos y los años bisiestos).

**Precisión del reloj:** Variación de  $\pm 120$  segundos o menos por mes a la temperatura normal.

**Datos impresos:** Fecha/hora

**Color de impresión:** Naranja

Datos basados en el Método de Pruebas Estándar de Canon. Sujetos a cambios sin previo aviso.

## [V] Specifications

---

### *General*

**Type:** 35 mm fully automatic lens-shutter camera.

**Lens:** Canon 38mm f/3.5.

**Shooting Distance Range:** 0.65m/2.1ft to infinity

**Viewfinder:** Albada type inverted Galilean finder.

**Viewfinder magnification:** 0.37X

**Shutter:** Programmed electromagnetically-driven shutter also serves as diaphragm.

### *Autofocus*

**AF Control:** Active autofocus system.

### *Automatic Exposure Mechanism*

**AE Control:** Programmed system

**Metering Range:** (at ISO 100)

**Flash-ON mode:** 1/60, f/3.5~1/250, f/22 (EV9.5-17)

**Flash-OFF mode:** 1/8, f/3.5~1/250, f/22 (EV7-17)

#### *Film Handling*

**Film Speed Setting:** ISO 25~3200 automatically set in 1 stop increments according to DX code; non-DX-coded film set to ISO 25.

**Film Loading:** Automatic (automatic blank film advance is not carried out with non-DX or ISO 25 film).

**Film Winding:** Automatic

**Film Rewinding:** Automatic at end of film, stops automatically when finished

**Frame Counter:** Frame number disc. (Sequentially counts up or down coupled with the film movement)

#### *Flash*

**Built-in Flash:** Equipped with red eye reduction lamp.

**Flash Coupling Range:** (at ISO 100)  
0.65~4m (2.1~13.1 ft)

**Recycling Time:** Approx 4 sec.

**Flash Firing:** Flash-OFF, Flash-ON, Flash-ON with Red Eye Reduction

**Self-timer:** Electronically-controlled 10 second delay timer activated by pressing the self-timer button. The red-eye reduction/Self-timer lamp blinks during operation.

#### *Power Source*

**Battery:** One 3V lithium battery (CR 123 A/DL 123A)

**Shooting Capacity:** Approx. 18 rolls of 24-exp film with 50% flash use.

#### *Size*

**Dimensions:** 125(W) × 68(H) × 38(D) mm/  
4-15/16" × 2-11/16" × 1-1/2"

**Weight:** 220 gr/7.8oz (without battery for the camera)

**Additional Specifications for the SURE SHOT MAX DATE**

**Imprint Function:** Built-in date imprinting function using a transmission type LCD and automatic calendar programmed with dates until year 2019 (compensates automatically for long and short months and

leap years).

**Clock Precision:** Variation of  $\pm 120$  seconds or less per month at normal temperature.

**Imprint Data:** Date/time

**Imprint color:** Orange

All data are based on Canon's Standard Test Method. Subject to change without notice.

This device complies with Part 15 of the FCC Rules. Operation is subject to the following two conditions: (1) This device may not cause harmful interference, and (2) this device must accept any interference received, including interference that may cause undesired operation

Do not make any changes or modifications to the equipments unless otherwise specified in the instructions. If such changes or modifications should be made, you could be required to stop operation of the equipments

These equipments has been tested and found to comply with the limits for a class B digital device, pursuant to part 15 of the FCC Rules. These limits are designed to provide reasonable protection against harmful interference in a residential installation. This equipment generates, uses and can radiate radio frequency energy and, if not installed and used in accordance with the instructions, may cause harmful interference to radio communications.

However, there is no guarantee that interference will not occur in a particular installation. If this equipment does cause harmful interference to radio or television reception, which can be determined by turning the equipment off and on, the user is encouraged to try to correct the interference by one or more of the following measures:

- Reorient or relocate the receiving antenna.
- Increase the separation between the equipment and receiver.
- Consult the dealer or an experienced radio/TV technician for help.

This digital apparatus does not exceed the Class B limits for radio noise emissions from digital apparatus set out in the Radio Interference Regulations of the Canadian Department of Communications.

Le présent appareil numérique n'émet pas de bruits radioélectriques dépassant les limites applicables aux appareils numériques (de la classe B) prescrites dans le Règlement sur le brouillage radioélectrique édicté par le ministère des Communications du Canada.